

AppliedVR | VRx

User Manual.

THERAPEUTIC VRx PLATFORM | Pico G2 4K | VERSION 3.0

Contact us
avr-research.zendesk.com | research@appliedvr.io | +1 (844) 204-9093

Table of Contents (Home Page)

Health & Safety Warnings	3
What's Inside	6
Get to Know Your System	7
Power: On/Off	8
Use Your Gaze to Make Selections	9
Getting Started	10
Reorientation Button	14
Settings Menu	15
Connect to WiFi	16
In-App Menu	18
Battery Levels	23
Power: Headset	24
Power: Controller	25
Controller Connection	26
Care & Cleaning Instructions	27
Troubleshooting	29
Customer Support	31

Health & Safety Warnings

Before using VR, please read and follow all product safety and operating instructions. Failure to follow these guidelines can result in personal injury (including electric shock, fire, and others), damage to property, and even death. If you allow others to use this product, you are responsible for ensuring that each user is aware of and follows all product safety and operating instructions.

Familiarize yourself with the potential risks and side effects associated with VR. These may include motion sickness, dizziness, eye strain, headaches, or other visual abnormalities.

A small number of people (up to 0.025% of users) may experience seizures or severe symptoms (eg: disorientation, nausea, fainting) upon viewing the VR experience. **If you suffer from epilepsy, please consult your doctor before use.**

If you experience seizures, loss of consciousness, convulsions, claustrophobia, involuntary movements, vertigo, nausea, dizziness, drowsiness, eye pain or discomfort, visual abnormalities (hallucinations, ambiguity, or diplopia), itching, swelling or other discomfort discontinue use and seek medical assistance.

Please ensure you are in good health before using the product. Consult with your doctor if you are pregnant, elderly, suffer from serious physical, mental, visual or heart diseases or another serious medical condition.

Children 12 or under are not recommended to use VR. Medical supervision is required for the use of VR by children under the age of 12.

This product may emit radio waves that interfere with nearby electronic devices. If you are wearing a pacemaker or other implanted medical device, do not use it until you consult a doctor or medical device manufacturer.

Use only in a safe environment. This product creates an immersive virtual reality experience that blocks your view of your actual surroundings. Please move to a safe and comfortable area and take care of your surroundings. Do not get close to dangerous areas like stairs, windows, heat source or other hazardous areas.

When using the controller, please make sure that there is enough clearance to extend your arms around your head and body. Please hold the controller firmly to avoid injury or damage to those around you.

Do not operate the device at high volume for extended period of time to protect your hearing.

Use the charging equipment supplied with the product. Do not attempt to replace the battery yourself. Doing so may cause damage to the battery, overheating, fire, or personal injury. The battery may only be replaced by Pico or an authorized service provider.

The headset contains a lithium ion battery and the controller contains alkaline batteries. Recycle and dispose of the equipment properly according to local laws. Keep the device away from excessive humidity and extreme temperatures and avoid direct sunlight or ultraviolet radiation.

Do not disassemble, replace or repair equipment on your own. Unauthorized tampering will void your warranty. If you need repair service for your AppliedVR Device, please contact us at: research@appliedvr.io or +1 (844) 204-9093.

Prolonged use may cause dizziness or eye fatigue; **it is recommended that you take a break every 30 minutes.**

For more information visit: www.pico-interactive.com/us/terms/user_safety.html

Warning

Do not expose the lenses to direct sunlight.

Extra care should be taken when the headset is placed outdoors, on a balcony, windowsill or in the car. Exposure to direct sunlight for **less than 1 minute** may cause permanent yellow spots on the screen.

Attention: The physical damage caused by the above is not covered by warranty.

Important Notes

Protect the optical lenses during use and storage to prevent sharp objects from scratching the lenses.

Nearsighted users can use this product with their glasses according to the wearing instructions.

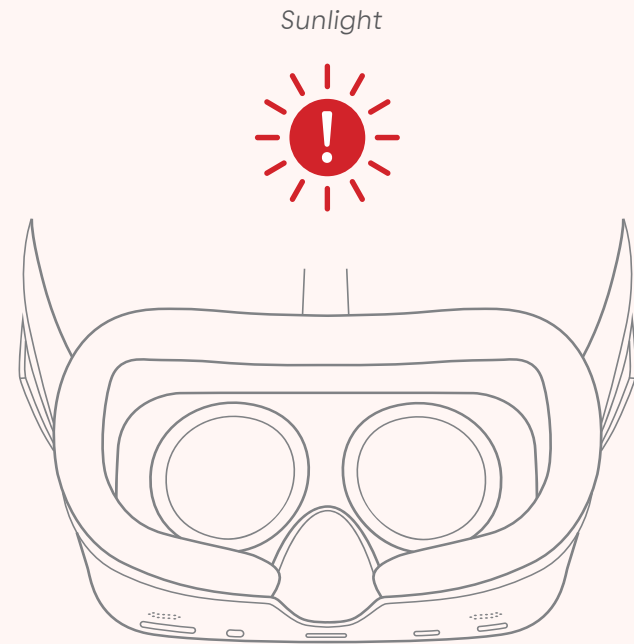

What's Inside

- Pico G2 4K headset, with Amplifier™
- Handheld Controller
- USB-C Charging Cord and Wall Charger
- Quick Guide
- Carrying Case



Headset Face View



Headset with Amplifier™



Quick Guide Example

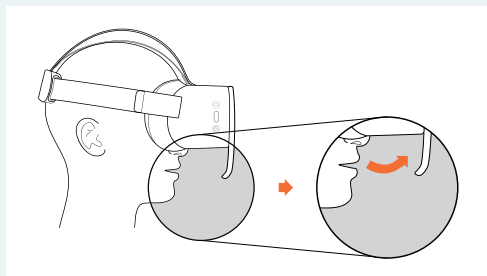



The **Amplifier*** is a custom attachment, designed to help amplify the sound of your breath. When you exhale through your mouth, the Amplifier directs your breath toward the microphone. Certain modules are responsive to these sounds and allow you to visualize your breath in VRx.

*Patent Pending. For more info, see appliedvr.io/patents

Get to Know Your System

Headset

-  **MENU** button brings up the In-App Menu if it is pressed while in an experience
-  **SELECT** button can be used to make a selection
-  **HOME** button brings you home, the home button will also recenter the headset if held down

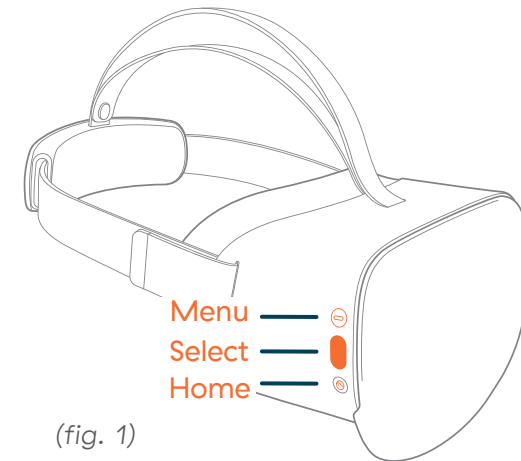

(fig. 1)



(fig. 1)

Handheld Controller (optional)

The handheld controller has multiple buttons that provide quick access to menus and features:

-  **SELECT** button can be accessed by soft pad and/or the index finger button
- +/- VOLUME** button adjusts the volume up and down
-  **MENU** button brings up the In-App Menu if it is pressed while in an experience
-  **HOME** button brings you home; the home button will also recenter the headset if held down

(fig. 2)

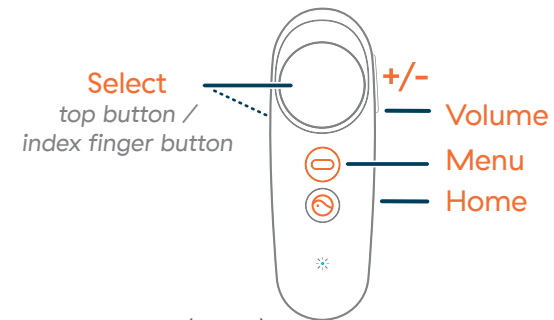

(fig. 2)

Charging the Device

The USB-C input port is located on the bottom of the device. Please plug the USB-C cable into the device, connect the other end of the cable into the power adapter, and plug your power adapter into a power outlet. The Status Indicator LED flashes a **RED** light when battery is low. (fig. 3)

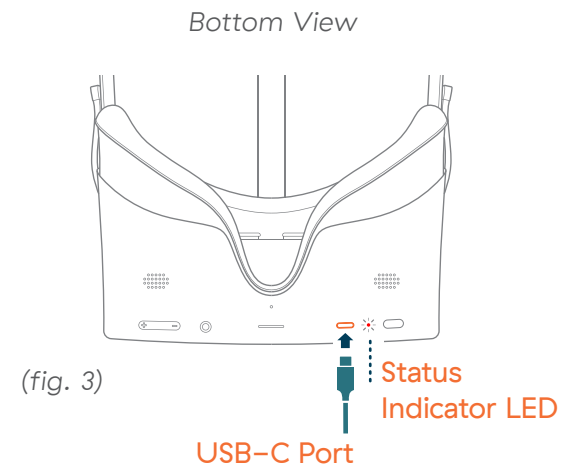

(fig. 3)

Power: On/Off

Powering On

Long press the  POWER button on the bottom of the headset and wait for the **BLUE** LED light to turn on. The blue loading screen will appear in the headset followed by the Home Menu. (fig. 1)

Powering Off

When you take off your headset, it will go to sleep after not being used. To wake it back up, put your headset back on.

To turn the headset off completely

Long press the  POWER button for a full **3 seconds** until the screen goes black. The Controller will go to sleep on its own. (fig. 2)

CARE: Store the headset in its case when not in use to prevent damage.

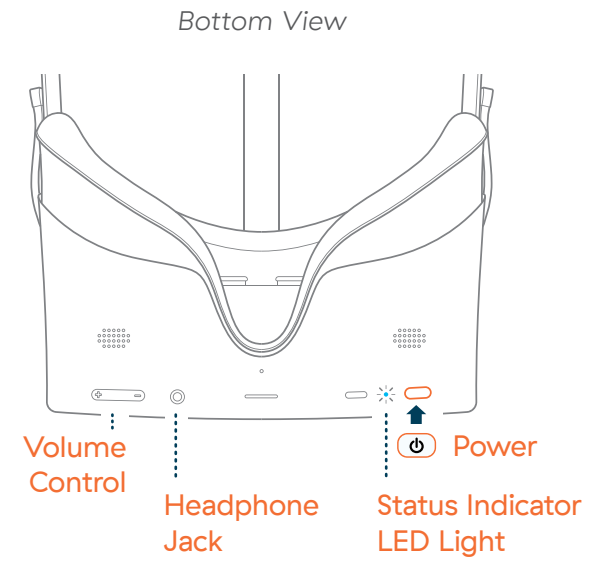

(fig. 1)

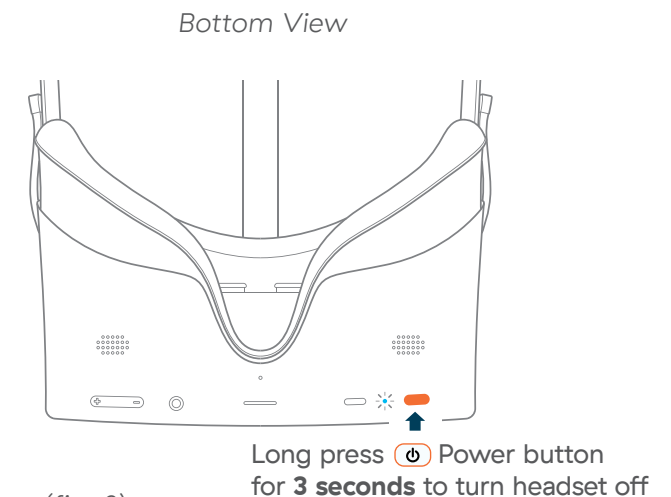

(fig. 2)

Use Your Gaze to Make Selections

We developed **GAZE-BASED** controls to keep you from being tethered to a controller, and to make our system more accessible to those with limited mobility. (fig. 1)

How does it work?

In this mode, the **CURSOR** follows the motion of your head. **Simply look** around to move the cursor until it lands on the button you want to activate.

How do I make selections?

Move the **CURSOR** so that it **hovers over the button** you'd like to activate. When the button fills up (in about 2 seconds), your selection will be activated. You can also press the **SELECT** button on the right side of the headset. (fig. 2)

Optional Handheld Controller

Alternatively, you can use the handheld controller to navigate and make selections in VR. Your controller has multiple buttons for you to use. (fig. 3)

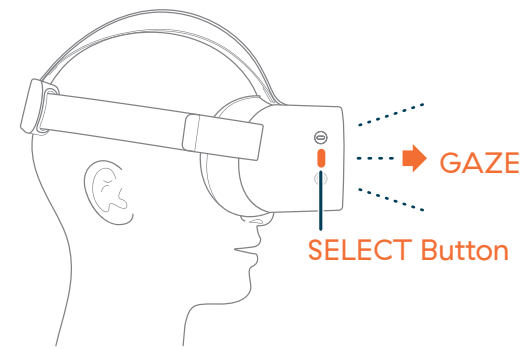

(fig. 1)

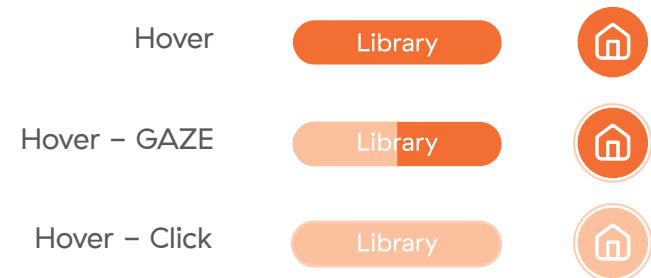

(fig. 2)

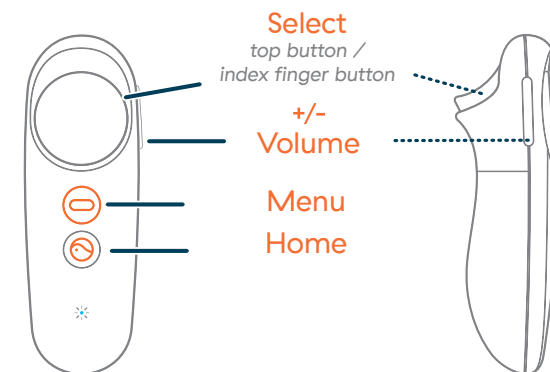

(fig. 3)

Getting Started

1 Power On.

Long press the  POWER button on the bottom of the headset and wait for the Status Indicator LED to turn on a **BLUE** light. (fig. 1)

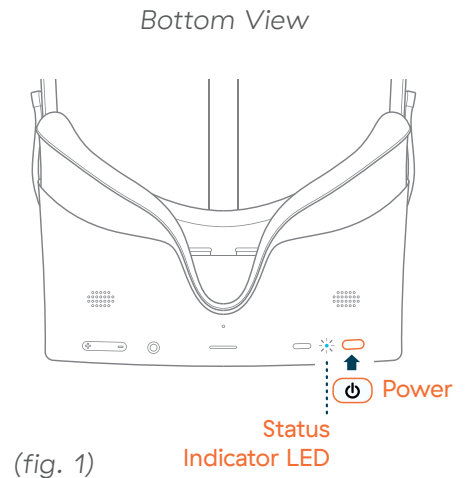

2 Put on the headset.

Adjust the side straps so the headset fits comfortably. Check to make sure your view is clear. (fig. 2)

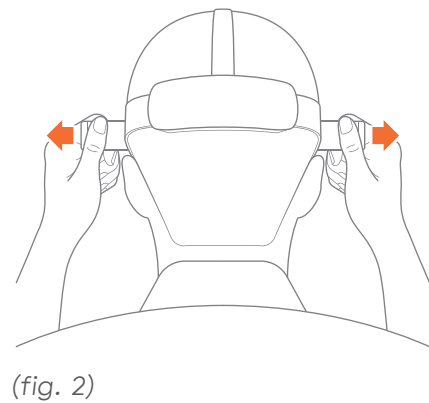

A. To wear headset with glasses, hold the headset up to your face, over your glasses, then slide the head strap over the back of your head. (fig. 3)

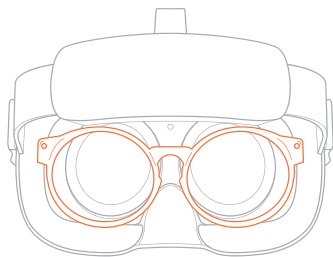

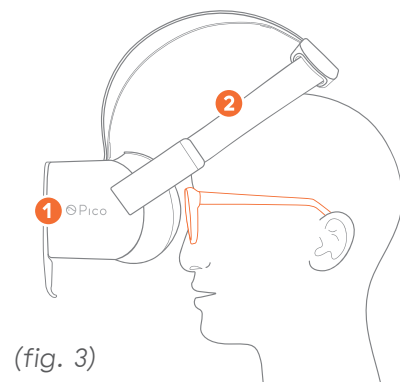
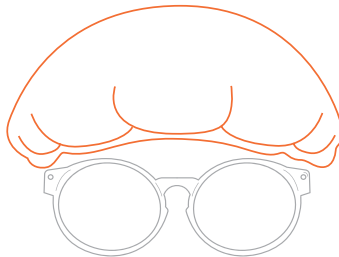

B. If sharing a device with others, put on a bouffant hair cover before putting on headset.



Getting Started (cont'd)

3 Choose your Input Mode.

Once the menu (fig. 1) loads a prompt will appear for you to select your Input Mode. Using  **GAZE-MODE**, you can make your selection:

- A. **To use your gaze** – Hover over the **GAZE MODE** button to select it.
- B. **To use the controller** – Hover over the **CONTROLLER MODE** button to select it. Follow the prompts on screen to connect your controller.
 - i. **Connecting your controller** – Press the  **HOME** button on your controller once to connect it.
 - ii. **Recenter your controller** – Point your controller forward. HOLD down the  **HOME** button on the controller until the check mark appears – do not lightly press once. (fig. 2)
 - iii. **Select preferred hand** – Use your **index finger button** (not the Home Button) to select LEFT or RIGHT.

TIP: To change your Input Mode, in the main menu select the  **SETTINGS** icon & then select the **INPUT SETTINGS** button. Select the alternate Input Mode and hand preference button on the right to change. (fig. 3)

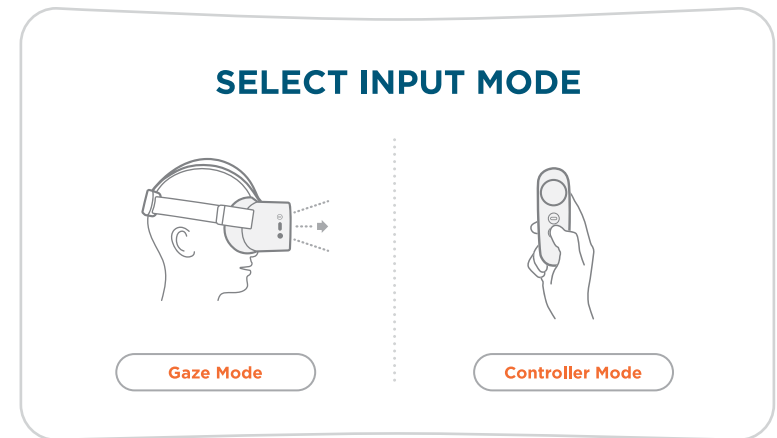

(fig. 1)

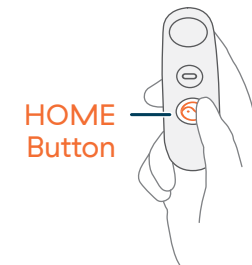

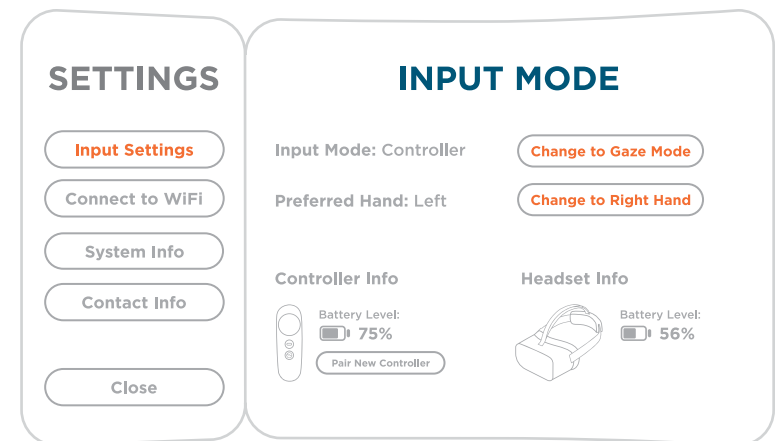

(fig. 2) Point Forward





(fig. 3)







Getting Started (cont'd)

4 Connect to WiFi.

- A. Use  GAZE to focus and activate the  SETTINGS icon at the lower center of the Home Menu.
- B. Use  GAZE to focus and activate CONNECT TO Wi-Fi icon. You'll temporarily be taken out of the VRx interface.

★ **NOTE:** Use both  GAZE MODE and  SELECT button to connect to Wi-Fi. (fig. 1)
SELECT button is the middle button on exterior right side of headset.

- C. Once in the new environment, use  GAZE to focus on your network. Press  SELECT button to confirm. (fig. 2)
SELECT button is the middle button on exterior right side of headset.

- D. Enter password and connect. (fig. 3)
 - 1 Enter password. Focus on each letter with  GAZE. You must press the  SELECT button to confirm after each individual letter.
 - 2 Use  GAZE to focus on  return symbol (bottom right). Press  SELECT button to confirm.
 - 3 Use  GAZE to focus on CONNECT, press  SELECT button on headset.

- E. Once connected, use  GAZE to focus on the round EXIT button, press  SELECT button on headset **two times.** (fig. 4)

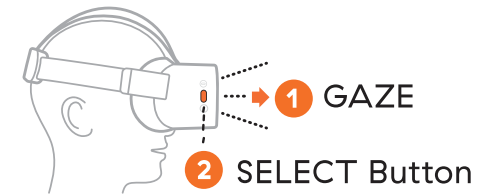

(fig. 1)



(fig. 2)

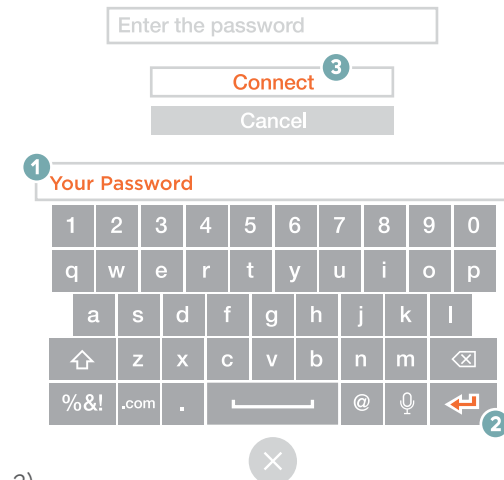

(fig. 3)



(fig. 4)

Getting Started (cont'd)

5 Select the VRx Session.

Enter the VRx session by selecting the module tile on the Home menu. (fig. 1)

6 Once you complete the VRx session, the next experience will automatically appear on the home screen.

7 Powering Down.

At the end of the session, press and hold the  POWER button for a full **3 seconds** until the screen goes black. The Controller will go to sleep on its own. To ensure the headset is charged and ready for your next use, make sure you plug the headset back into the USB-C charger.

- Alternatively, once you take the headset off you can let the headset go to sleep on its own.

CARE: Store the headset in its case when not in use to prevent damage.



(fig. 1)

This is a general example, your specific Virtual Reality experience may differ.

Navigation: Reorient Button

Reorientation

Recenter the screen to your view with the  COMPASS icon. Should your screen be facing the wrong way, you can use this option to bring it back to center. It also allows you to lie down or sit back while in an experience.

Note: If you use VRx while laying down, we recommend resting your head on a pillow rather than laying fully flat.

To reorient:

1. Select the  COMPASS icon. It appears in the Home Menu and the In-App Menu. (fig. 1)
2. A window will pop up and ask you to relax and look forward. Adjust to a more comfortable position. (fig. 2)
3. The interface will automatically adjust after **5 seconds**.

Note: You can also hold down the  HOME button on the headset to reorient. (fig. 3)



(fig. 1)

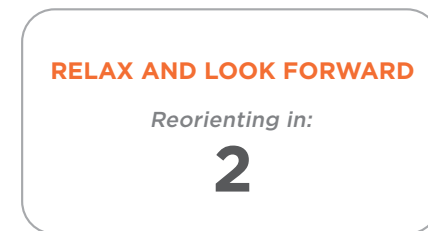

(fig. 2)

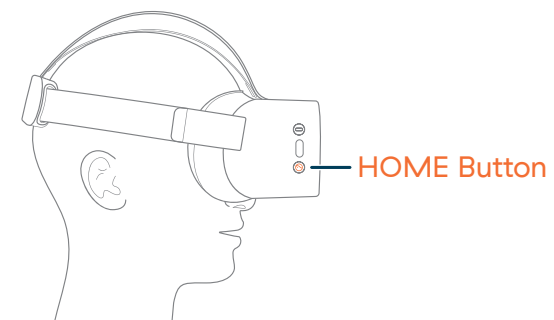

(fig. 3)

Navigation: Settings Menu

Settings Menu

The Settings Menu can be accessed by selecting the  SETTINGS icon in the bottom center of your screen. In the Settings Menu, you can change your controller settings, connect to Wi-Fi, check system information, find your device ID, and find the AppliedVR support team's contact info.

Input Settings

Change your Input Mode by selecting the INPUT SETTINGS button in the Settings Menu. (fig. 1)

- A. If you're in **gaze mode**, you can change to controller mode by selecting the CHANGE TO CONTROLLER MODE button. Follow the prompt to recenter the controller. You can also choose which side the controller appears on by changing the Preferred Hand option.
- B. If you're in **controller mode**, you can switch hands, pair a new controller, change to gaze mode, and check your controller battery levels by selecting the choices from the menu.

In the Input Settings screen, you can also **check your battery levels** of the headset and controller (if paired). (fig. 2)

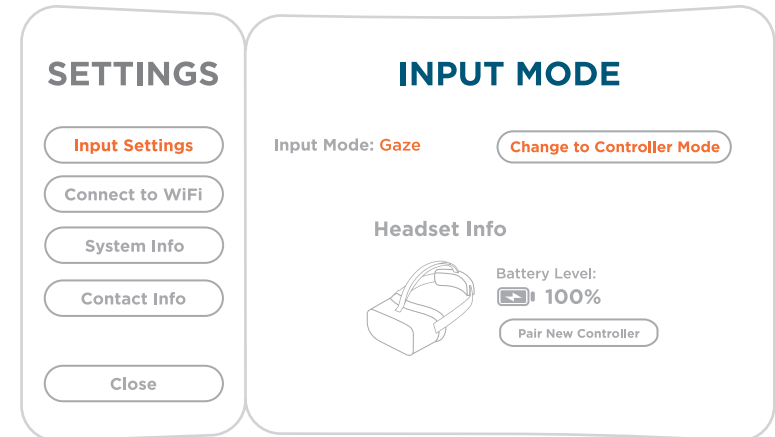

(fig. 1)

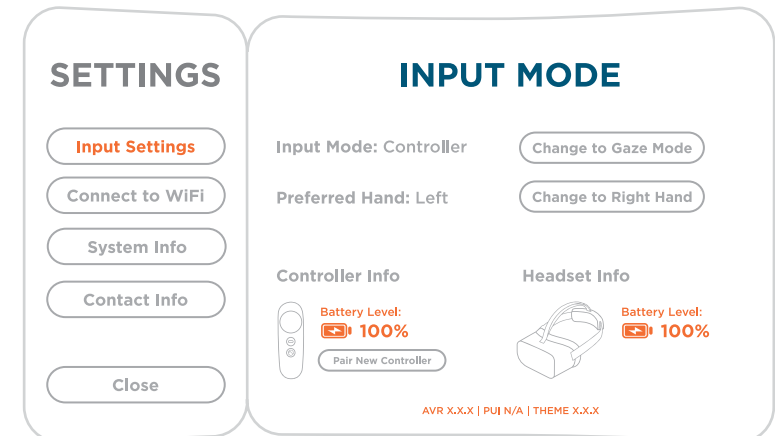





(fig. 2)



Navigation: Settings Menu (cont'd)



Connect to Wi-Fi

- A. Use  GAZE to focus and activate the  SETTINGS icon at the lower center of the Home Menu.
- B. Use  GAZE to focus and activate CONNECT TO Wi-Fi icon. You'll temporarily be taken out of the VRx interface. (fig. 1)

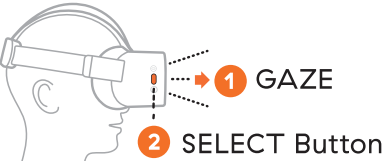
★ NOTE: Use both  GAZE MODE and  SELECT button to connect to Wi-Fi.



SELECT button is the middle button on exterior right side of headset.

- C. Once in the new environment, look for your Wi-Fi network. If you don't see yours, make sure to scroll down by using the arrows to the right. Use  GAZE to focus on your network. Press  SELECT button to confirm. (fig. 2)
(*SELECT button is the middle button on exterior right side of headset.*)

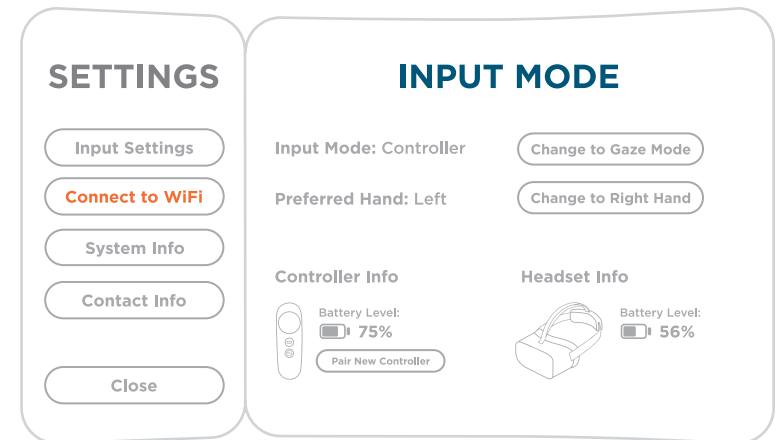

(fig. 1)



WLAN

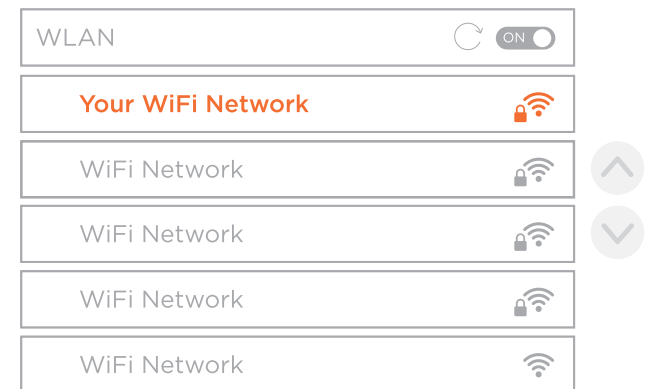











(fig. 2)

Navigation: Settings Menu (cont'd)

Connect to Wi-Fi (cont'd)

D. Enter password and connect. (fig. 1)

- 1 Enter password. Focus on each letter with  GAZE. You must press the  SELECT button to confirm after each individual letter. You will see the character added to the password bar right above the keyboard. To delete a character, simply  GAZE at the back arrow and press the Select button. If you need a special character, select that on the lower left of the keyboard.
- 2 Use  GAZE to focus on  return symbol (bottom right). Press  SELECT button to confirm. The full password should appear now below the name of your network.
- 3 Use  GAZE to focus on CONNECT, press  SELECT button on headset. WiFi should be connected!

E. Once connected, you should see a green “check mark” to the left of the Wi-Fi network. Use  GAZE to focus on the round  EXIT button, press  SELECT button on headset **two times**. (fig. 2)

Clicking the SELECT button once will prompt a message that says “Press again to exit”. Press the SELECT button again, will return you to the VR interface.

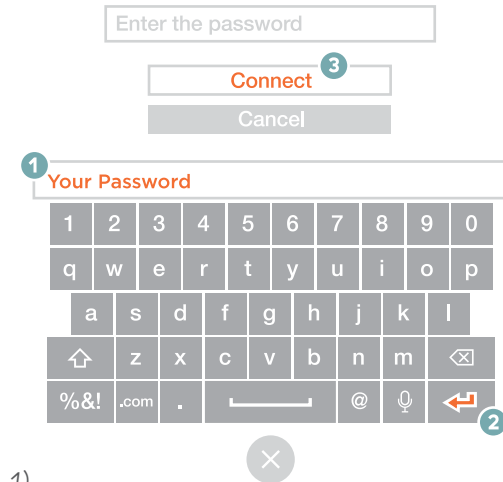

(fig. 1)



(fig. 2)

Navigation: Settings Menu (cont'd)

Contact Info

Select the CONTACT INFO button to find your Device ID, the support team's contact information, and to reset progress of the device. Your Device ID and contact information can be helpful if you contact customer support for troubleshooting assistance.

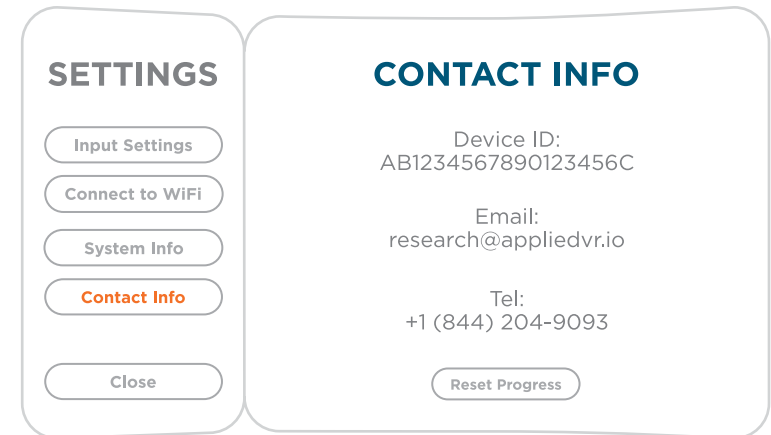

(fig. 1)





WARNING: If you are participating in a research study, **DO NOT** reset progress without the explicit direction of a member of the research team.

Navigation: In-App Menu

In-App Menu to navigate through VRx

Need to adjust the volume, reorient your controller, or return home once you are in a module? Access those functions through the In-App Menu.

In-App Menu

1. Select the In-App  ANCHOR icon which can be found in the lower center of your screen to launch the menu. (fig. 1) You can also press the  MENU button on the right of the headset to access this.

Alternatively, if you are using the controller, you can press the  MENU button on the controller.

2. Once you're in the In-App Menu, you can learn more about the module you're in, adjust the volume, reorient your controller, or return home by selecting the icon for each. (fig. 2)



(fig. 1)

This is a general example, your specific Virtual Reality experience may differ.

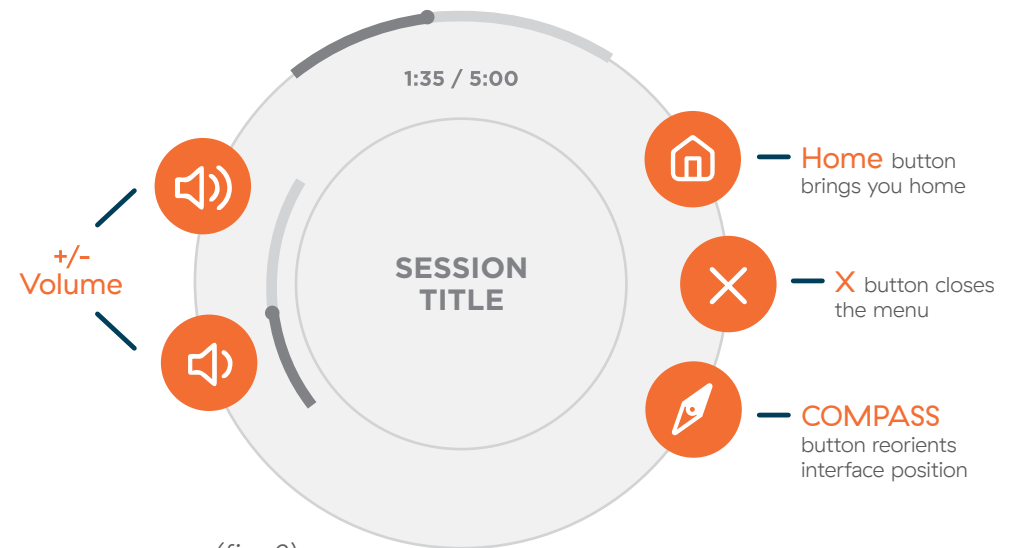

(fig. 2)

Navigation: Pause Menu

Pause Menu

Need to take off your headset in the middle of an experience? The Pause Menu will appear once you put your headset back on.

In the Pause Menu, you can go home, resume the experience, restart the experience, and read more about the experience you're in. (fig. 1)

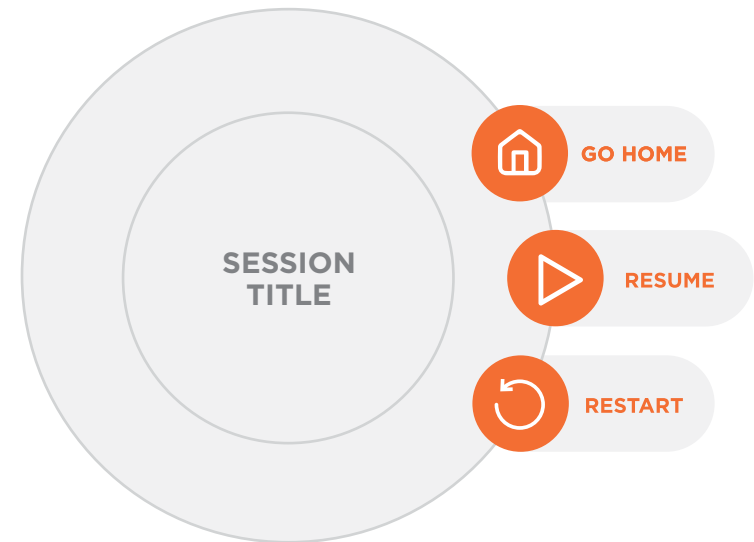

(fig. 1)

Navigation: VRx Sessions

Once you complete a VRx session, the next experience will automatically appear on the home screen. (fig. 1)

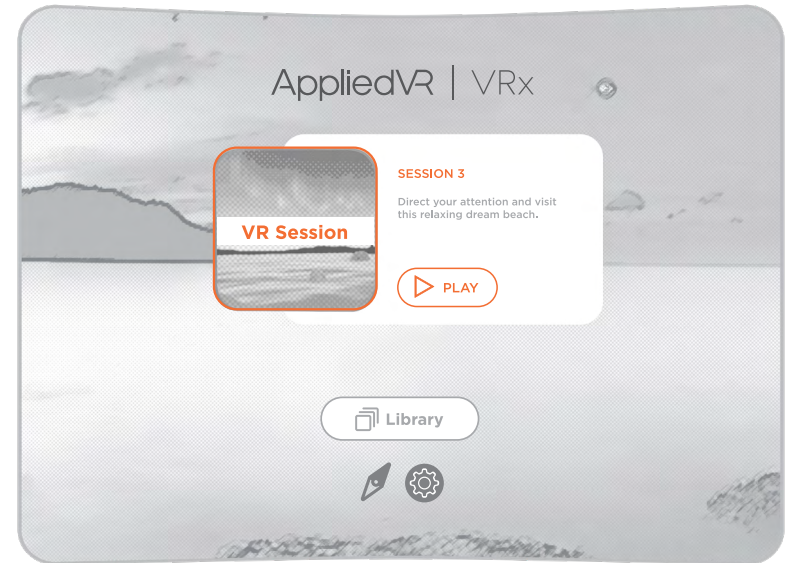

(fig. 1)

This is a general example, your specific Virtual Reality experience may differ.

NOTE: Be sure to view the experiences in order of VRx sessions schedule, if one was provided by the research team.

Content Library

To find the Library, click the  LIBRARY button on the bottom of the Home menu. (fig. 1)



(fig. 1)

The Library lists all the experiences offered on your therapeutic VR platform, separated by category. (fig. 2)

NOTE: Not all AppliedVRx products have a  LIBRARY.

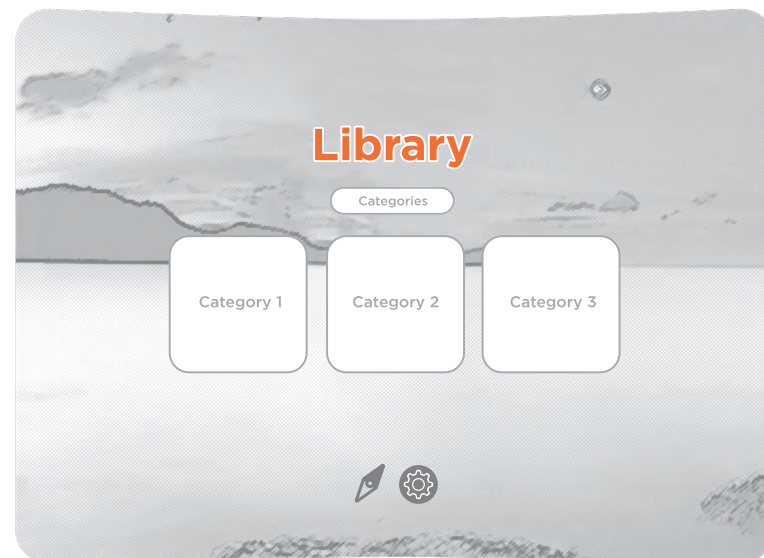

(fig. 2)

These images are general examples, your specific Virtual Reality experience may differ.

Battery Levels

Check Battery Levels

You can **check the battery level** of both your headset and your paired controller in the INPUT SETTINGS screen within the main menu. It can be accessed by selecting the  SETTINGS icon in the bottom center of your screen. (fig. 1)

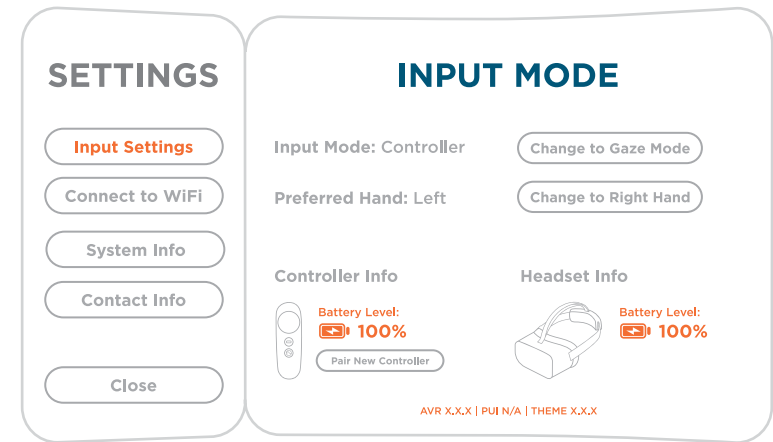

(fig. 1)

Power: Headset

Charging the Headset

The headset battery will last approximately 2.5 hours when playing content.

Use the adapter and cable provided in your kit to charge the headset. The charging port is located on the bottom of the headset. (fig. 1)

Note: The headset only charges when you are not wearing it. Ensure that the proximity sensor in the headset is not covered, otherwise the headset will not charge.

Status indicator LED lights – Battery Levels

- GREEN – Charged
- BLUE – Halfway Charged
- RED – Low
- ▨ BLINKING RED – Extremely Low

*The battery is not user replaceable or serviceable.

Do not attempt to open your headset to access the battery.

TIP: For best results, we recommend leaving your device plugged in after each use. This ensures it will be ready to go whenever you need to use it.

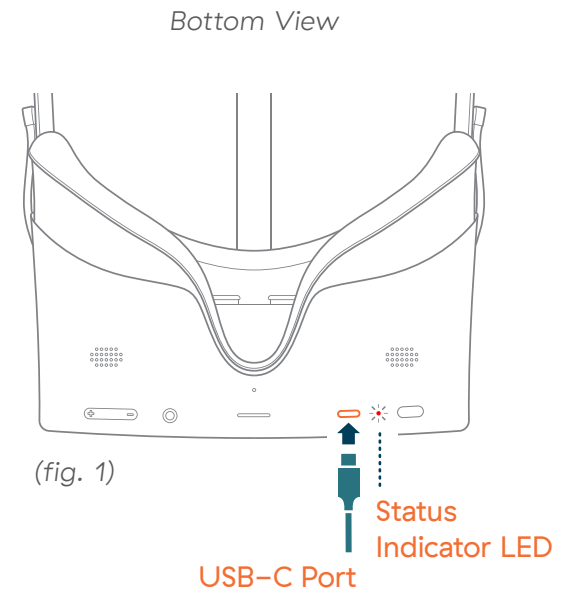

Power: Controller

Battery Life

Your controller uses two **AAA batteries** and should last a couple of months, depending on how frequently it's used.



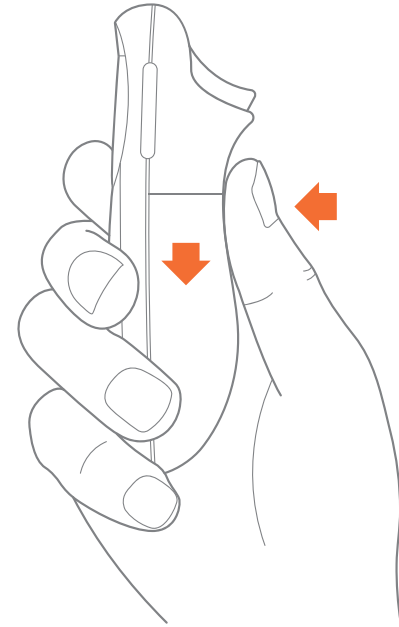

To replace the batteries, press and push down on the bottom half of the controller to open the compartment. Remove the old batteries and replace them with new AAA batteries. Slide the compartment door back into place. (fig. 1)



(fig. 1)

Controller Connection

Pair New Controller

1. Go to the  SETTINGS menu. In INPUT SETTINGS, select PAIR NEW CONTROLLER. (fig. 1)
2. The Controller Connection screen will appear. Using the  SELECT button on the headset, select PAIR NEW CONTROLLER.
3. The New Controller Pairing screen will appear. Follow the instructions on the screen by pressing the  HOME button on the controller you want to pair.
4. Once you press the  HOME button on the controller you are pairing, a checkbox with a **4 character ID** for your controller will appear. Using the  SELECT button on the headset, check the checkbox next to the **4 character ID**, and then select PAIR. (fig. 2)
5. The controller will then be paired with the headset. Select EXIT to return to the VRx settings menu.

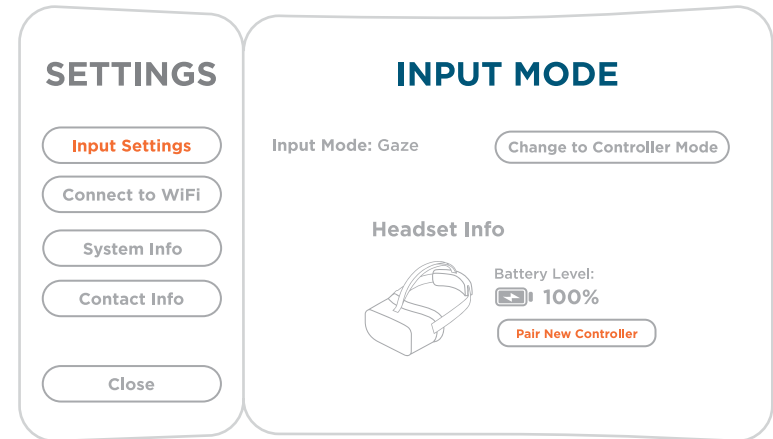

(fig. 1)

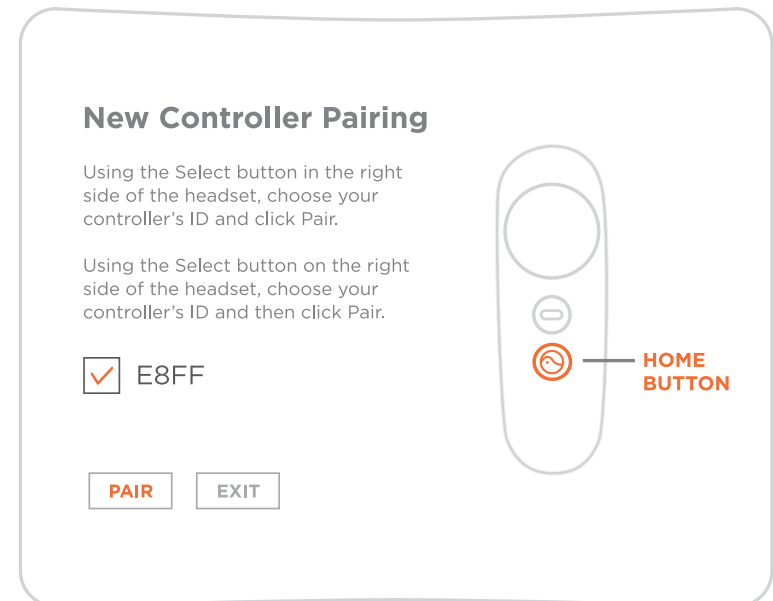

(fig. 2)

Care & Cleaning Instructions

1 Before Use

If sharing a device with others, put on a **bouffant hair cover** before putting on headset. (fig. 1)

2 Headset

After using the headset, wipe all non-porous surfaces, including the top straps, the back head-pad, and the headset enclosure with an approved disinfectant wipe. (i.e. Super Sani-Cloth®)

Allow surfaces to remain wet for the duration specified on the packaging of the wipes.

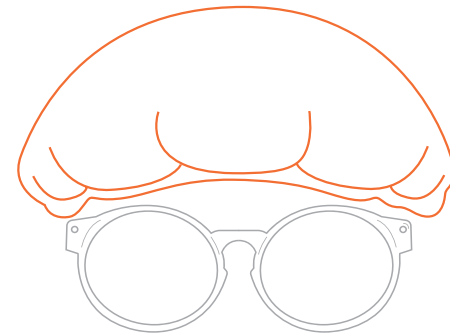

(fig. 1)

WARNING: Do not expose the headset to direct sunlight.

Care & Cleaning Instructions (cont'd)

3 Face Cushion & Care

- If face cushion is covered with a **non-porous surface** wipe with approved disinfectant wipe and allow to remain wet for the duration specified on the packaging of the wipes.
- If face cushion has a **porous foam surface**, replace the foam face cushion between each patient.

Follow the illustration and stick the face cushion into the headset slit along the edge. (fig. 1)

- Use a small amount of alcohol and wipe the lens from the center to the outer edge. (fig. 2)
- Store headset in the provided case.
- Replace headset components when they become compromised through regular wear and tear.

Face cushion meets infection control standards:

Care and cleaning instructions have been developed with top medical institutions and are in line with the Center for Disease Control's (CDC) Infection Control Guidance.*

*www.cdc.gov/sars/guidance/1-infection/healthcare.html

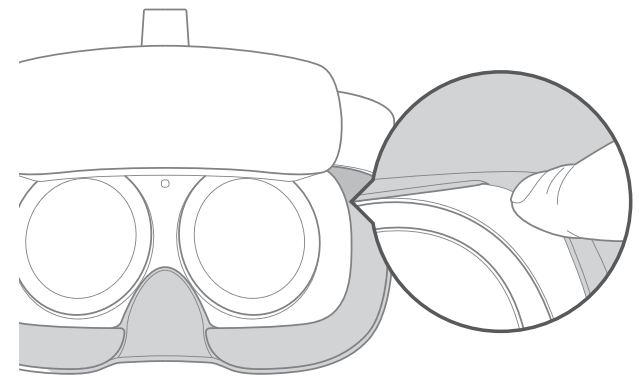

(fig. 1)

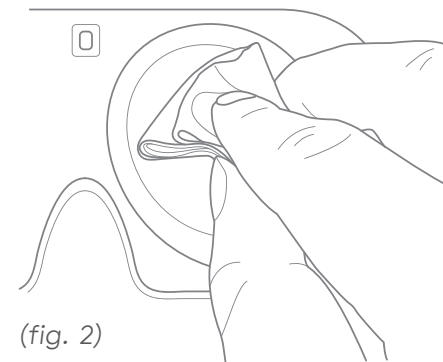

(fig. 2)

Troubleshooting

Headset not powering on?

Make sure the headset is completely plugged in. If the battery is completely drained, allow **two hours** to fully charge.

Unpaired Controller?

If your controller becomes unpaired, follow the instructions on [page 26](#) to pair the controller again.

Controller not visible or pointing the wrong way?

Press and hold the  HOME button on the controller while pointing the controller forward to reposition it. (fig. 1)

Blurry visuals?

If the screen appears blurry, adjust the headset up and down the face until the view comes into focus. Adjust the straps if necessary. (fig. 2)



Point Forward

(fig. 1)

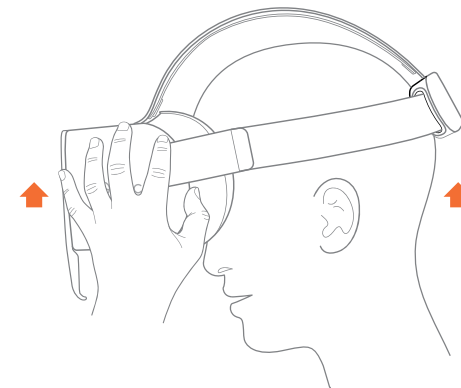

(fig. 2)

Troubleshooting

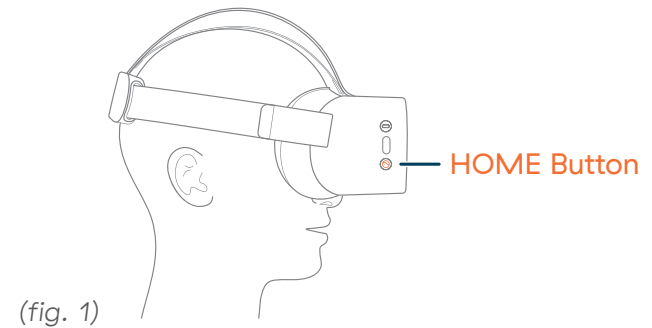
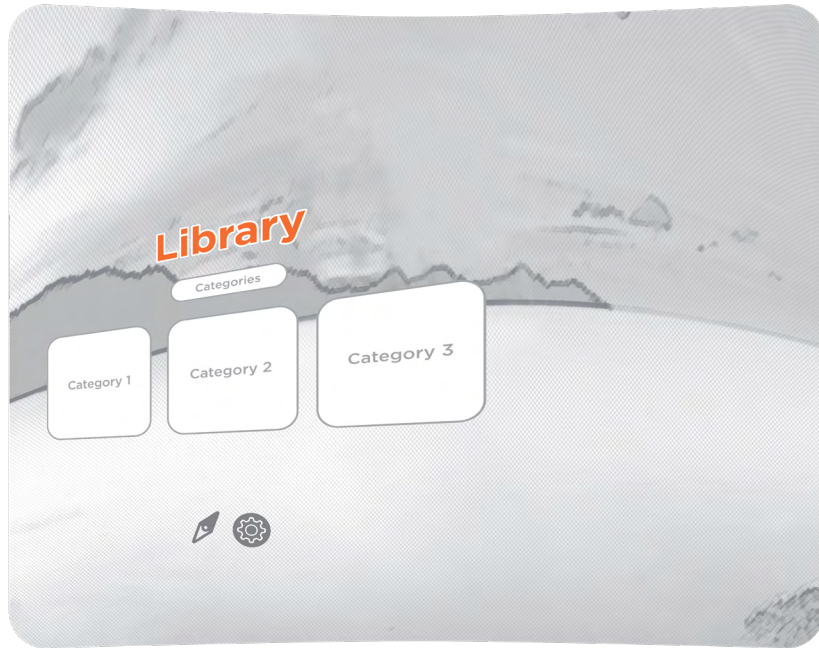



Lower Center of Home Menu



Menu pointing the wrong way?

There are **3 ways** to correct reorientation:

1. Look forward and level your gaze. Press and hold the  HOME button on the right hand side of the headset to reorient the menu. (fig. 1)
2. Select the  COMPASS icon in the menu. (fig. 2)
3. You can remove and put back on the headset and it will reorient itself. (fig. 3)

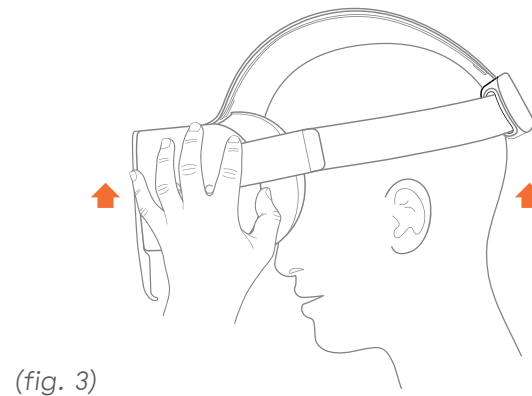

Customer Support

For any other questions or for more support contact our support desk!
We have a helpful team ready to answer any and all questions.

Thank you for choosing AppliedVR!

USER MANUAL FOR THERAPEUTIC VR PLATFORMS:
EaseVRx

avr-research.zendesk.com | research@appliedvr.io | +1 (844) 204-9093

AppliedVR | VRx

For questions or help with your
AppliedVR device, please visit:

avr-research.zendesk.com

or contact us:

research@appliedvr.io | +1 (844) 204-9093